

Key Features

Everything within Reach | Enhanced Touchscreen

Performance | myViewBoard™ Annotation Software |

ViewBoard Cast Content Sharing Software | Enhanced

Viewing Comfort



Product Description

Featuring 4K Ultra HD resolution and an advanced, next-generation touchscreen, the ViewSonic® ViewBoard® IFP5550 delivers incredible collaborative capabilities for 21st century boardrooms and classrooms. With integrated myViewBoard® annotation software and ViewBoard Cast streaming software, content creation and sharing has never been easier. What's more, this ENERGY STAR certified display delivers optional slot-in PC capability for more computing-intensive interactive applications. A VESA-compatible design allows for installation on a wall mount, or on an optional trolley cart for more flexible installation in classrooms and meeting rooms.

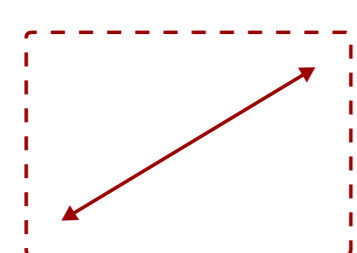
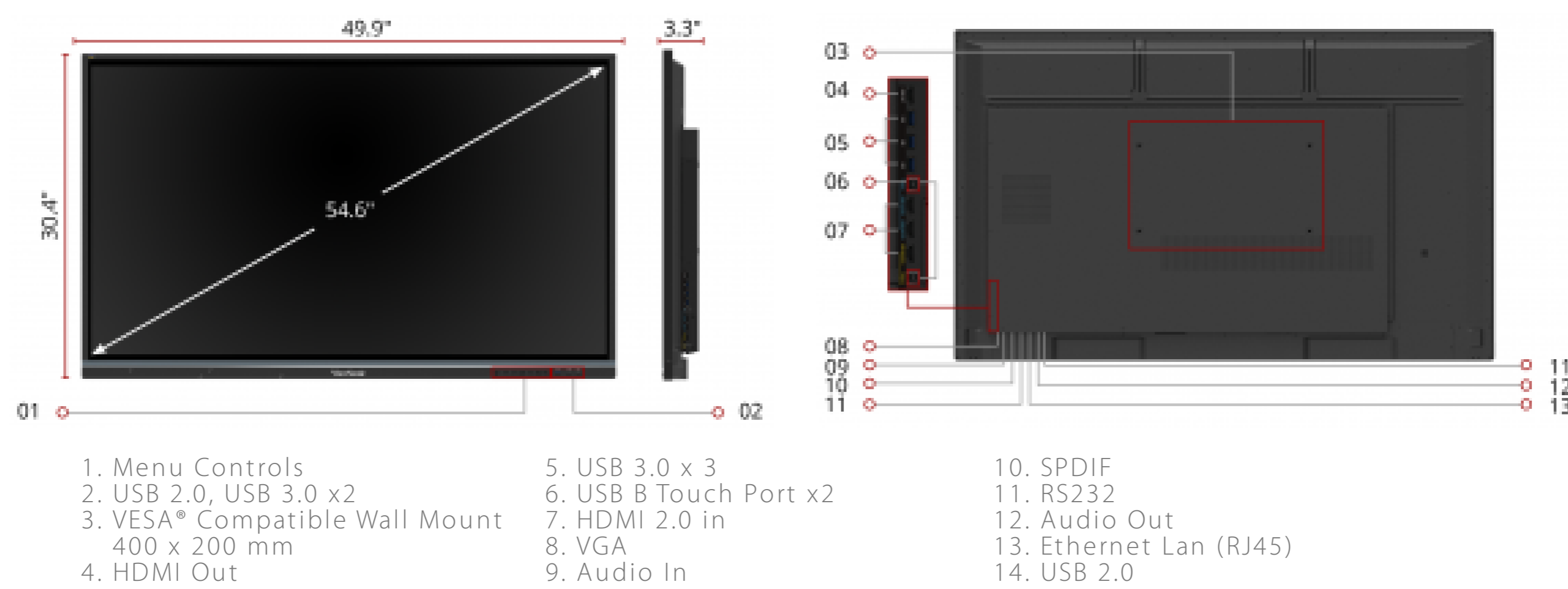

55"
DISPLAY

RESOLUTION

20-Point
TOUCH
INTERACTIVE

Contact Sales

call: 888.881.8781

email: salesinfo@viewsonic.com

visit: viewsonic.com

LCD Display:

Display Size (in.):	55
Viewable Area (in.):	54.6
Light Source:	LED
Resolution:	3840 x 2160
Aspect Ratio:	16:9
Static Contrast Ratio:	1,200:1
Dynamic Contrast Ratio:	5,000:1
Backlight Life (Hours):	50,000
Brightness:	350 cd/m2
Response Time (Typical GTG):	8ms
Viewing Angles:	178° horizontal, 178° vertical
Panel Surface:	Anti-glare 7H tempered glass
Operation Rating:	16/7

Networking:

Ethernet LAN:	10/100/1000 Mbps
---------------	------------------

Embedded Player:

OS:	ViewBoard OS (embedded Android 8)
GPU:	ARM Mali-G51
CPU:	ARM Quad Core A73 + A53
CPU Processor Speed:	A73: 1.1GHz, A53: 1.5GHz
Memory:	3GB
Storage:	32GB

Audio:

Internal Speakers:	10W (x2)
Subwoofer:	15W (x1)

Connector:

HDMI 2.0 In(3), HDMI Out(1), VGA(1), Composite RCA(1), 3.5mm Audio In(1), 3.5mm Audio Out(1), SPDIF Audio Out(1), USB 3.0(4), USB 2.0(3), Slot-in PC Slot(1), USB B Touch Port(2), RS232(1), Ethernet LAN (RJ45)(1), WIFI Module Slot(1)

Power:

Voltage:	100-240 VAC
Consumption (max):	350W
Consumption (typical):	81W
Stand-by:	<0.5W

Operating Conditions:

Temperature:	32-104° F (0 - 40° C)
Humidity (non-condensing):	10-90%

Touch:

Touch Technology:	Infrared
Touch Points:	20-Point Touch
Tip Detection:	Dual tips, 3mm and 8mm

Weight (imperial):

Net (lbs):	68.34
Gross (lbs):	85.98

Weight (metric):

Net (kg):	31.0
Gross (kg):	39.0

Dimensions (imperial) (WxHxD):

Packaging (in.):	56.2 x 34.6 x 8.7
Physical (in.):	49.9 x 30.4 x 3.3

Dimensions (metric) (WxHxD):

Packaging (mm):	1428.0 x 878.0 x 220.0
Physical (mm):	1268.0 x 773.0 x 85.0

Mount:

VESA Compatible:	400 x 200 mm
------------------	--------------

General:

Warranty: 3-year limited warranty on parts, labor and backlight, onsite warranty

Recycle/Disposal: Please dispose of in accordance with local, state or federal laws.

PACKAGE CONTENTS: IFP5550 display, stylus pen x 2, power cable, HDMI cable, USB cable, AV cable, remote control with batteries, Camera plate, M8 screw x 8, Quick Start Guide

Regulations: cTUVus, FCC, ENERGY STAR, Mexico Energy, CE, CB, RoHS, ErP, WEEE

UPC: 766907938814

Accessories:

IFP-EW-50-01, IFP-EW-50-02, IFP-EW-50-03, IFP-EW-50-04, LB-WIFI-001, NMP660, PD-IFP-001, PD-IFP-002, PD-IFP-003, PD-IFP-004, SW-071, SW-072, SW-073, SW-074, SW-075, SW-101, VB-CAM-001, VB-STND-001, VB-STND-002, VB-STND-003, VB-STND-004, VB-VIS-001, VB-WKB-001, VPC15-WP-4, VPC15-WP-6, VPC16-WP-4, VPC17-WP-6, WMK-047-2